

ALGEMENE KENMERKEN:

- Rack & pinion pneumaat
- Verdraaiing 90° ±5°
- Slagbegrenzerregeling ±5°
- Werktemperatuur: -30 °C ~ 100 °C
- Stuurdruk: 3 ~ 8 bar
- Koppeling volgens ISO 5211 en DIN 3337 (achthoekige insert)
- Opbouw van magneetventielen volgens Namur Std.
- Opbouw van naderingschakelaars volgens Namur

FIGUUR:
ADA: dubbelwerkend

ASR: enkelwerkend, normaal gesloten

ASRO: enkelwerkend, normaal open

ONTWERP	
Opbouw van magneetventielen	NAMUR Std.
Opbouw van toebehoren	NAMUR VDI, NAMUR VDE 3845 Std.
Aansluiting	ISO 5211, DIN 3337
TESTEN EN CERTIFICATEN	
Veiligheid	ATEX II 2 GD, SIL3
Kwaliteit	CE/PED, ISO9001

TYPE 10: (dubbelwerkend)

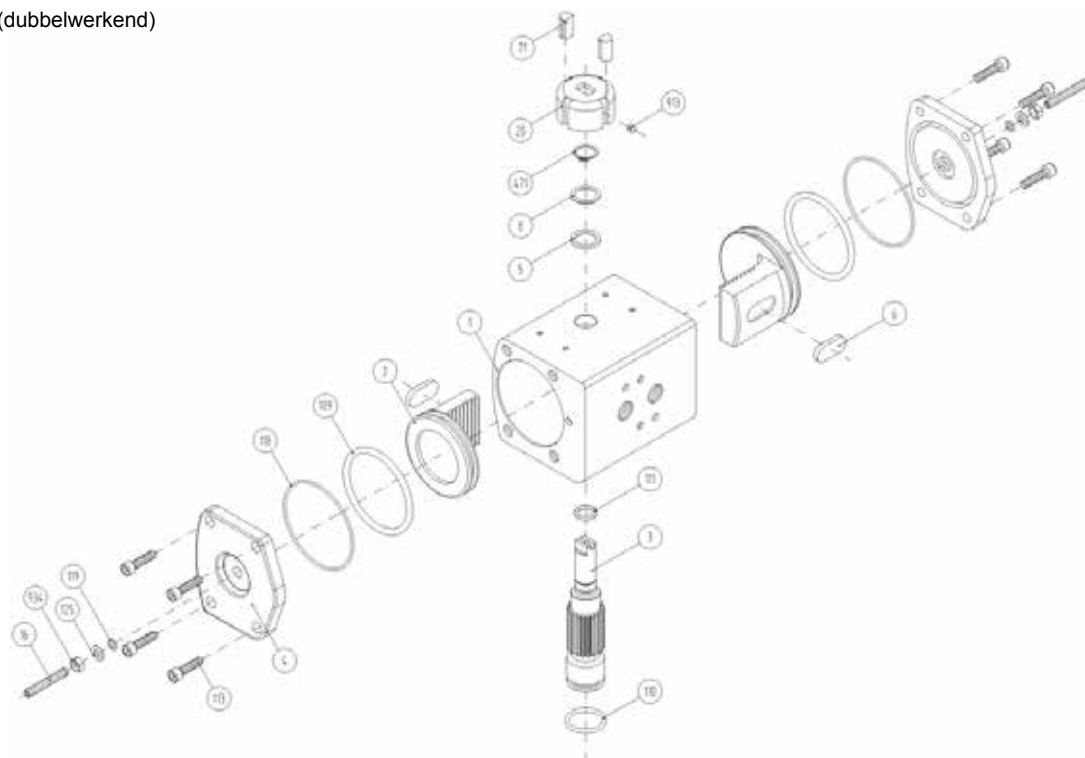
MATERIALEN:

Item	Omschrijving	Materiaal	Item	Omschrijving	Materiaal
1	Huis	Aluminium hard geanodiseerd	109	O-Ring	NBR
2	Zuiger	Aluminium	110	O-Ring	NBR
3	As	Vernikkeld staal	111	O-Ring	NBR
4	Eindkap	Aluminium Epoxy gecoat	113	Bout	Roestvrijstaal
5	Veerrondel	Polyamide PA 6.6	118	O-Ring	NBR
6	Geleidingsring	Polyamide PA 6.6 + 30% G.F.	119	O-Ring	NBR
8	Veerrondel	Roestvrijstaal	125	Rondel	Roestvrijstaal
16	Instelbout	Roestvrijstaal	913	Bout	Roestvrijstaal
20	Visuele standmelder	Polyamide	471	Externe circlips	Roestvrijstaal
21	Nok	Polyamide	934	Moer	Roestvrijstaal

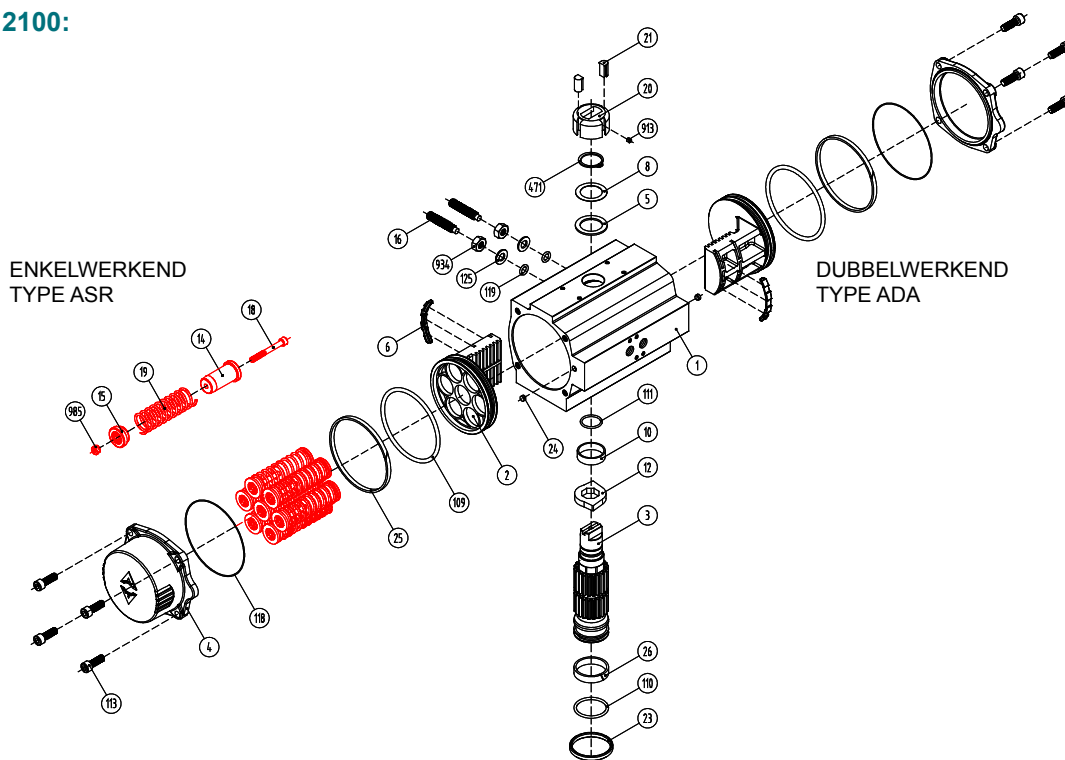
TYPE 20 - 2100:

MATERIALEN:

Item	Omschrijving	Materiaal	Item	Omschrijving	Materiaal
1	Huis	Aluminium hard geanodiseerd	23	Centreerring	Vernikkeld staal
2	Zuiger	Aluminium	24	Stop	NBR
3	As	Vernikkeld staal	25	Geleidingsring	Resin
4	Eindkap	Aluminium Epoxy gecoat	26	Lagerring	Hostalen RCH 1000
5	Veerrondel	Polyamide PA 6.6	109	O-Ring	NBR
6	Geleidingsring	Polyamide PA 6.6 + 30% G.F.	110	O-Ring	NBR
8	Veerrondel	Roestvrijstaal	111	O-Ring	NBR
10	Lagerring	Hostalen RCH 1000	113	Bout	Roestvrijstaal
12	Stop	ASTM A 105	118	O-Ring	NBR
14	(*) Veerbout	Polyamide PA 6.6	119	O-Ring	NBR
15	(*) Veerbout	Polyamide PA 6.6	125	Rondel	Roestvrijstaal
16	Instelbout	Roestvrijstaal	913	Bout	Roestvrijstaal
18	(*) Bout	Roestvrijstaal	471	Externe circlips	Roestvrijstaal
19	(*) Veer	DIN 2076 -D-5.6	934	Moer	Roestvrijstaal
20	Visuele standmelder	Polyamide	985	(*) Moer	Roestvrijstaal
21	Nok	Polyamide			

* Enkel voor ASR

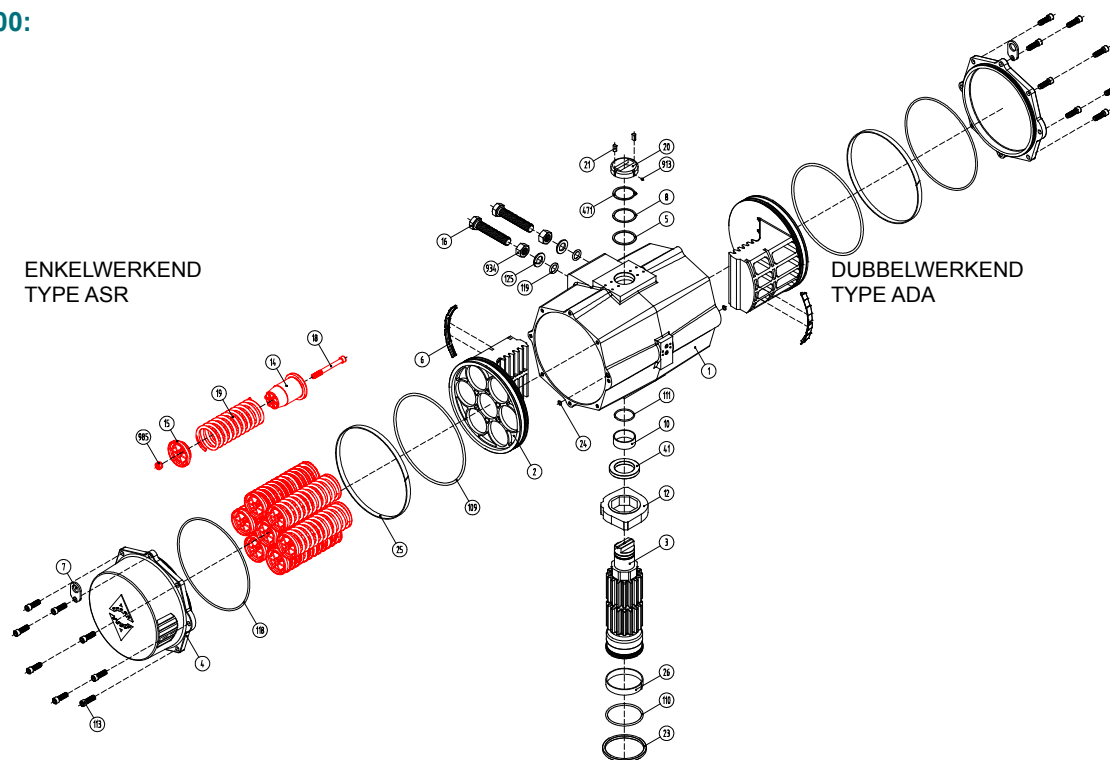
** Voor type 20: Polyamide PA 6.6 + 30% G.F.

TYPE 2500:

MATERIALEN:

Item	Omschrijving	Materiaal	Item	Omschrijving	Materiaal
1	Huis	Aluminium hard geanodiseerd	23	Centreerring	Vernikkeld staal
2	Zuiger	Aluminium	24	Stop	NBR
3	As	Vernikkeld staal	25	Geleidingsring	Resin
4	Eindkap	Aluminium Epoxy gecoat	26	Lagerring	Hostalen RCH 1000
5	Veerrondel	Polyamide PA 6.6	109	O-Ring	NBR
6	Geleidingsring	Polyamide PA 6.6 + 30% G.F.	110	O-Ring	NBR
8	Veerrondel	Roestvrijstaal	111	O-Ring	NBR
10	Lagerring	Hostalen RCH 1000	113	Bout	Roestvrijstaal
12	Stop	ASTM A 105	118	O-Ring	NBR
14	(*) Veerbout	Polyamide PA 6.6	119	O-Ring	NBR
15	(*) Veerbout	Polyamide PA 6.6	125	Rondel	Roestvrijstaal
16	Instelbout	Roestvrijstaal	913	Bout	Roestvrijstaal
18	(*) Bout	Roestvrijstaal	471	Externe circlips	Roestvrijstaal
19	(*) Veer	DIN 2076 -D-5.6	934	Moer	Roestvrijstaal
20	Visuele standmelder	Polyamide	985	(*) Moer	Roestvrijstaal
21	Nok	Polyamide			

* Enkel voor ASR

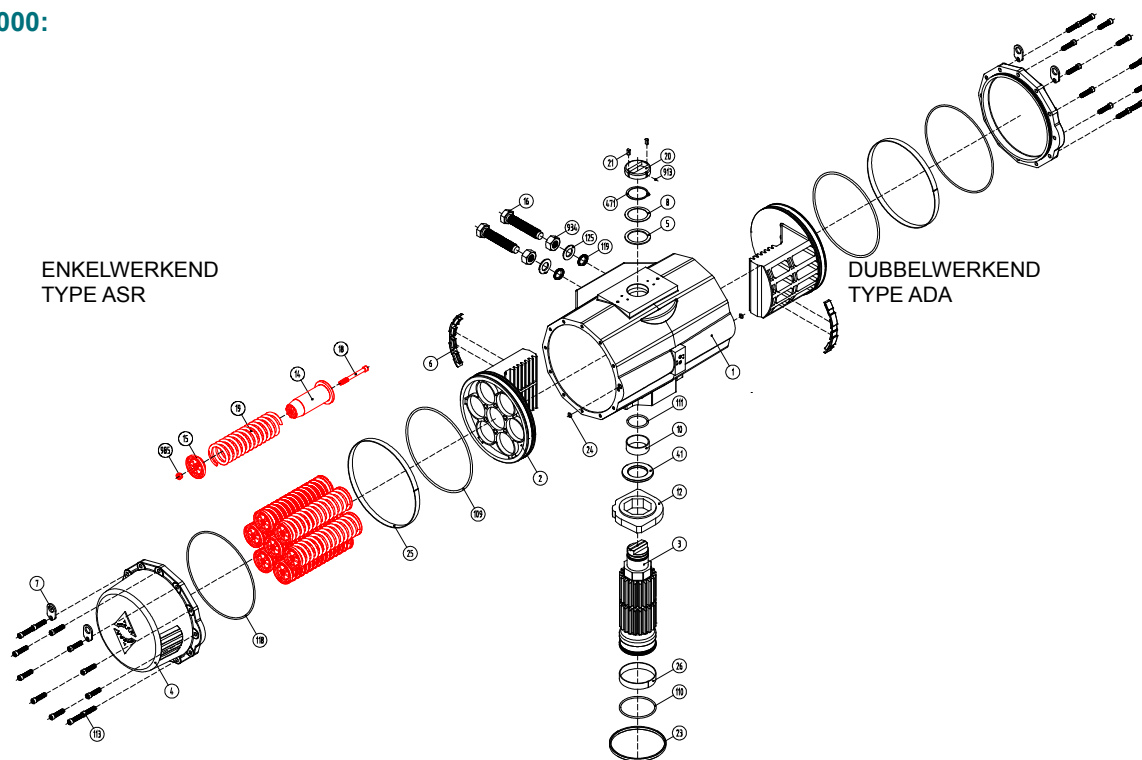
** Voor type 20: Polyamide PA 6.6 + 30% G.F.

TYPE 4000:

MATERIALEN:

Item	Omschrijving	Materiaal	Item	Omschrijving	Materiaal
1	Huis	Aluminium hard geanodiseerd	23	Centreerring	Vernikkeld staal
2	Zuiger	Aluminium	24	Stop	NBR
3	As	Vernikkeld staal	25	Geleidingsring	Resin
4	Eindkap	Aluminium Epoxy gecoat	26	Lagerring	Hostalen RCH 1000
5	Veerrondel	Polyamide PA 6.6	109	O-Ring	NBR
6	Geleidingsring	Polyamide PA 6.6 + 30% G.F.	110	O-Ring	NBR
8	Veerrondel	Roestvrijstaal	111	O-Ring	NBR
10	Lagerring	Hostalen RCH 1000	113	Bout	Roestvrijstaal
12	Stop	ASTM A 105	118	O-Ring	NBR
14	(*) Veerbout	Polyamide PA 6.6	119	O-Ring	NBR
15	(*) Veerbout	Polyamide PA 6.6	125	Rondel	Roestvrijstaal
16	Instelbout	Roestvrijstaal	913	Bout	Roestvrijstaal
18	(*) Bout	Roestvrijstaal	471	Externe circlips	Roestvrijstaal
19	(*) Veer	DIN 2076 -D-5.6	934	Moer	Roestvrijstaal
20	Visuele standmelder	Polyamide	985	(*) Moer	Roestvrijstaal
21	Nok	Polyamide			

* Enkel voor ASR

** Voor type 20: Polyamide PA 6.6 + 30% G.F.

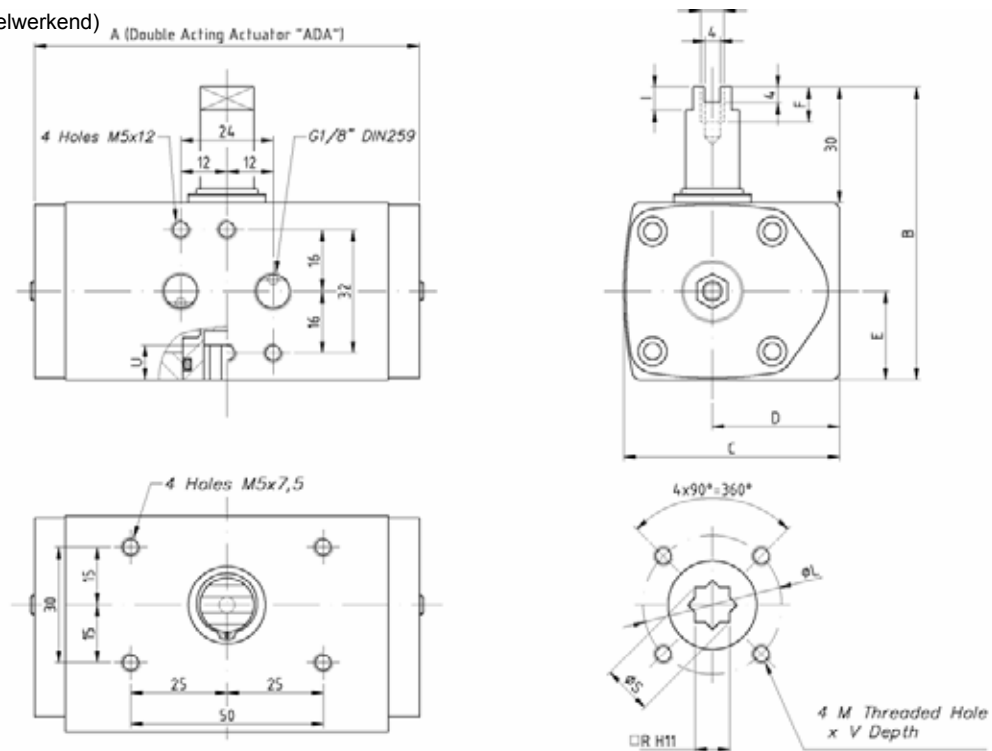
TYPE 10: (dubbelwerkend)



AFMETINGEN: (mm)

TYPE	A	B	C	D	E	F	I	R	ØS	ISO 5211	ØL	M x V	U
10	100	76	56	33	23	9	6	9	12,5	F03	36	M5x8	10

TYPE 20-1750:

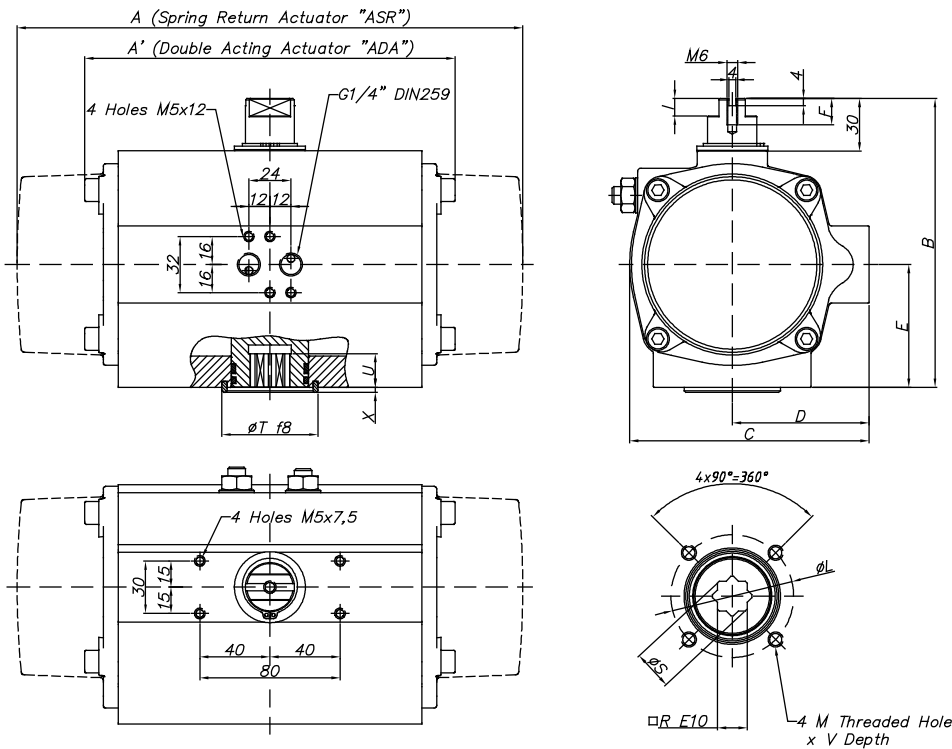

AFMETINGEN: (mm)

TYPE	A	A'	B	C	D	E	F	I	R	ØS	ISO 5211	ØL/ ØL1	M x V	ØT	X	U
C20	163,0	145	96	76,0	48	34	9	6	14	18,1	F04	42	M5x10	35	3	12
20F05	163,0	145	96	76,0	48	34	9	6	14	18,1	F05	50	M6x10	35	3	12
20VK09	163,0	145	96	76,0	48	34	9	6	9	12,5	F03	36	M5x8	25	2	10
											F05	50	M6x10			
40	195,0	158	115	91,0	56	45	9	6	14	18,1	F04	42	M5x10	35	3	12
40F05	195,0	158	115	91,0	56	45	9	6	14	18,1	F05	50	M6x10	35	3	12
80	217,0	177	137	111,0	66	55	12	8	17	22,5	F05	50	M6x10	55	3	19
											F07	70	M8x16			
130	258,0	196	147	122,0	71	60	15	8	17	22,5	F05	50	M6x10	55	3	22
											F07	70	M8x16			
200	299,0	225	165	135,5	78	70	15	10	17	22,5	F07	70	M8x16	55	3	23
											F10	102	M10x16			
300	348,5	273	182	152,5	86	80	16	12	22	28,5	F07	70	M8x16	70	3	24
											F10	102	M10x16			
500	397,0	304	199	173,0	96	85	17	15	22	28,5	F10	102	M10x16	70	3	32
850	473,0	372	221	191,5	106	98	15	15	27	36,5	F10	102	M10x17	85	3	39
											F12	125	M12x20			
1200	560,0	439	249	212,5	116	114	16	15	36	48,5	F10	102	M10x17	100	4	48
											F14	140	M16x26			
1750	601,0	461	280	242,5	131	130	16	15	36	48,5	F14	140	M16x26	100	4	50

Wijzigingen voorbehouden

TYPE 2100:

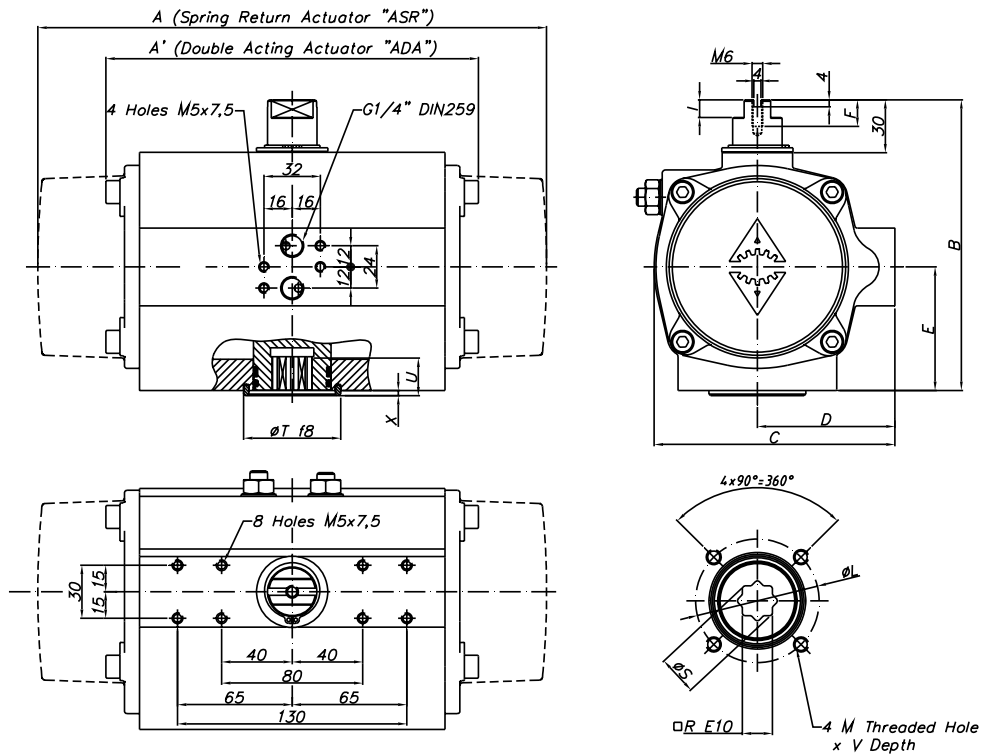

AFMETINGEN: (mm)

TYPE	A	A'	B	C	D	E	F	I	R	ØS	ISO 5211	ØL/ ØL1	M x V	ØT	X	U
C2100	702,0	510	313	276,5	148	147	16	15	46	65,1	F16	165	M20x29	130	4	50

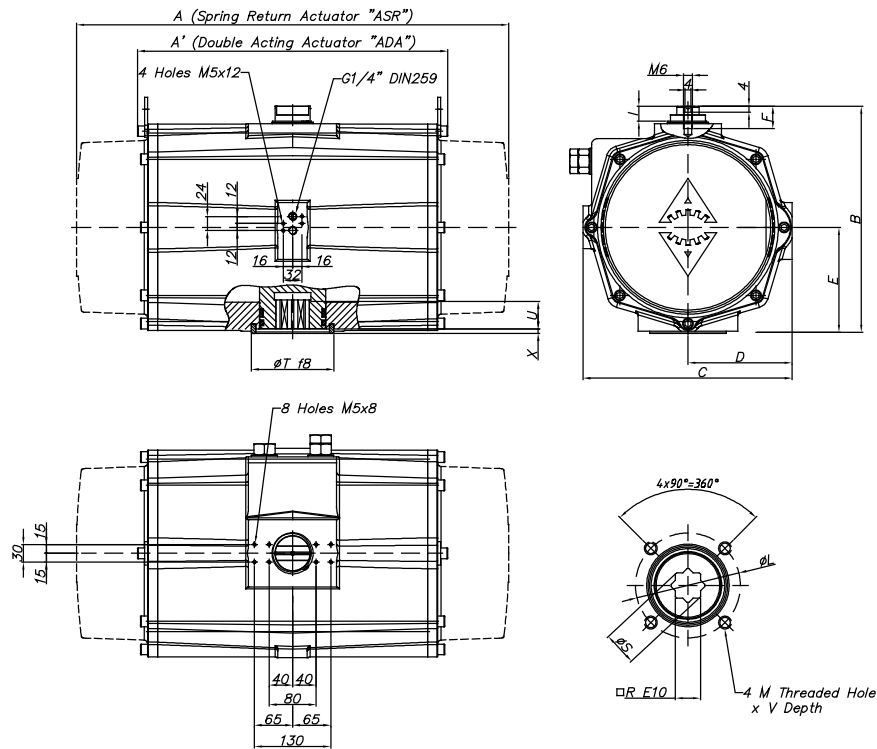
TYPE 2500:

AFMETINGEN: (mm)

TYPE	A	A'	B	C	D	E	F	I	R	ØS	ISO 5211	ØL/ ØL1	M x V	ØT	X	U
C2500	738,0	518	383	356,0	177,5	176,5	16	15	46	60,2	F16	165	M20x29	130	4	58

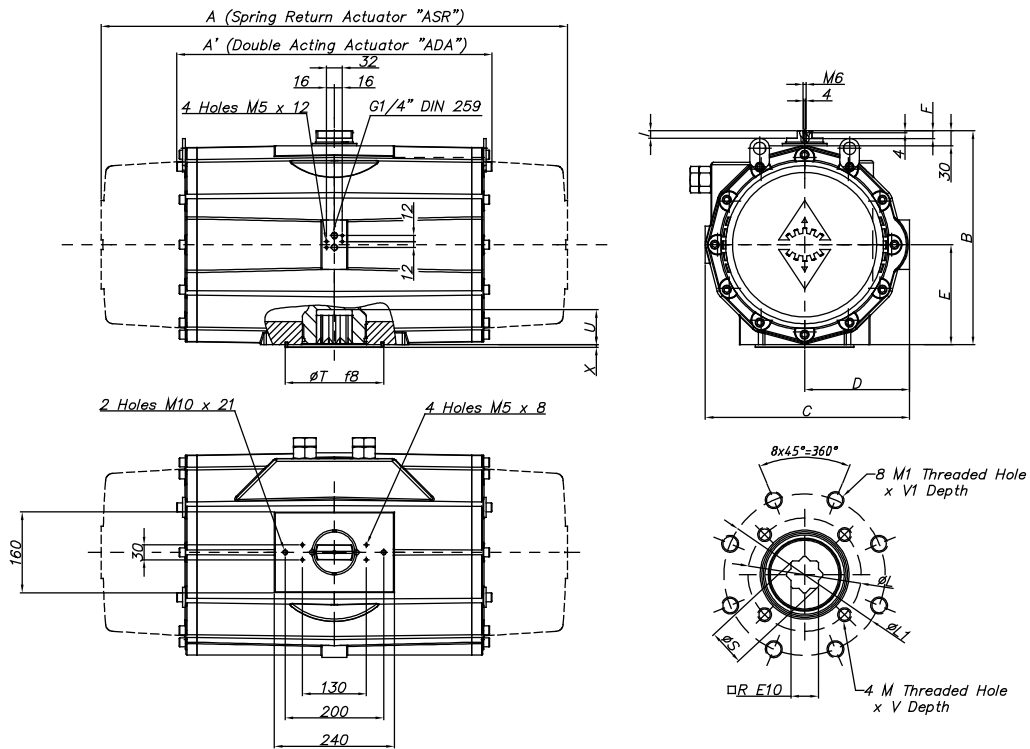
TYPE 4000:



AFMETINGEN: (mm)

TYPE	A	A'	B	C	D	E	F	I	R	ØS	ISO 5211	ØL	M x V	ØT	X	U
C4000	940,0	630	434	415,0	213	201	16	15	55	72,5	F16	165	M20x30	200	4	60
											F25	254	M16x30			

TYPE	Draaimoment voor dubbelwerkende pneumatische bediening in Nm																		Kg		
	3 bar		3,5 bar		4 bar		4,5 bar		5 bar		5,5 bar		6 bar		6,5 bar		7 bar			8 bar	
	0°	90°	0°	90°	0°	90°	0°	90°	0°	90°	0°	90°	0°	90°	0°	90°	0°	90°		0°	90°
10	6		8		9		10		11		11,5		12		12		13		14		0,6
20	9,7		11,4		13		14,6		16,2		17,8		19,5		21,1		23		26		1,4
40	20,3		23,7		27,1		30,5		33,9		37,3		41		44		47		54		2,1
80	38,5		44,9		51,3		57,7		64,1		70,5		77		83		90		103		3,0
130	59,1		68,9		78,7		88,6		98,4		108,3		118		128		138		157		3,8
200	88		102		117		131		146		161		175		190		205		234		5,6
300	145		170		194		218		242		267		291		315		339		388		8,5
500	217		253		289		325		361		397		433		469		505		577		11,2
850	359		419		479		538		598		658		718		778		837		957		16,9
1200	519		606		692		779		865		952		1038		1125		1211		1384		25,8
1750	707		824		942		1060		1178		1295		1413		1531		1649		1884		32,5
2100	1086		1267		1448		1629		1810		1991		2172		2353		2534		2896		49,0
2500	1730		2019		2307		2596		2884		3172		3461		3749		4038		4614		69,6
4000	2408		2809		3210		3612		4013		4414		4816		5217		5618		6421		129,4

TYPE	Verenpakket	Draaimoment voor enkelwerkende pneumatische bediening in Nm																		Veerslag		Kg		
		3 bar		3,5 bar		4 bar		4,5 bar		5 bar		5,5 bar		6 bar (A)		6,5 bar		7 bar		8 bar			EINDE	START
		0°	90°	0°	90°	0°	90°	0°	90°	0°	90°	0°	90°	0°	90°	0°	90°	0°	90°	0°	90°			
20	S04			8	5	9	7	11	8	13	10	14	12	16	13	17	15	19	17	22	20	4	7	1,5
	S06									11	7	12	9	14	10	15	12	17	13	20	17	7	11	1,5
	S08 (A)											10	5	12	7	14	9	15	10	18	14	9	15	1,6
40	S04	16	14	20	17	23	20	26	24	30	27	33	30	37	34	40	37	43	41	50	47	5	8	2,2
	S06	14	10	18	14	21	17	24	20	28	24	31	27	34	30	38	34	41	37	48	44	7	12	2,2
	S08			15	10	19	14	22	17	26	20	29	24	32	27	36	30	39	34	46	41	10	16	2,2
	S10							20	14	24	17	27	20	30	24	34	27	37	30	44	37	12	20	2,3
	S12									21	13	25	17	28	20	32	24	35	27	42	34	15	24	2,3
	S14 (A)											23	13	26	17	30	20	33	24	40	30	17	28	2,3
80	S04	31	27	38	34	44	40	50	46	57	53	63	59	70	66	76	72	82	78	95	91	9	13	3,3
	S06	27	21	34	28	40	34	47	41	53	47	59	53	66	60	72	66	79	73	92	86	13	20	3,4
	S08					37	29	43	35	49	41	56	48	62	54	69	61	75	67	88	80	17	27	3,4
	S10							39	29	46	36	52	42	59	49	65	55	71	61	84	74	22	33	3,5
	S12									42	30	48	36	55	43	61	49	68	56	81	69	26	40	3,6
	S14 (A)											45	31	51	37	58	44	64	50	77	63	30	47	3,7
130	S06	43	36	52	46	62	56	72	65	82	75	92	85	102	95	111	105	121	115	141	134	19	27	4,4
	S08			47	38	57	48	67	58	76	68	86	77	96	87	106	97	116	107	135	127	26	36	4,5
	S10					51	40	61	50	71	60	81	70	91	80	100	89	110	99	130	119	32	45	4,6
	S12							56	42	65	52	75	62	85	72	95	82	105	92	124	111	39	54	4,7
	S14 (A)											70	54	80	64	89	74	99	84	119	103	45	64	4,8
200	S06	61	49	76	63	90	78	105	92	119	107	134	122	149	136	163	151	178	166	207	195	31	46	6,5
	S08			67	50	81	65	96	79	111	94	125	109	140	123	154	138	169	152	198	182	42	61	6,7
	S10					72	52	87	66	102	81	116	96	131	110	146	125	160	139	189	169	52	77	6,9
	S12							78	53	93	68	107	83	122	97	137	112	151	126	180	156	63	92	7,0
	S14 (A)											99	70	113	84	128	99	142	113	172	143	73	107	7,3
300	S06	102	75	126	99	151	123	175	148	199	172	223	196	247	220	272	245	296	269	344	317	51	83	9,7
	S08			112	76	136	100	160	124	185	148	209	173	233	197	257	221	281	245	330	294	68	111	9,9
	S10					122	76	146	101	170	125	194	149	219	173	243	198	267	222	315	270	85	138	10,2
	S12							131	77	156	101	180	126	204	150	228	174	253	198	301	247	102	166	10,5
	S14 (A)											165	102	190	126	214	151	238	175	287	223	119	193	10,8

(A) Standaard

TYPE	Max. druk	Draaimoment voor enkelwerkende pneumatische bediening in Nm																		Veerslag		Kg		
		3 bar		3,5 bar		4 bar		4,5 bar		5 bar		5,5 bar		6 bar (A)		6,5 bar		7 bar		8 bar			EINDE	START
		0°	90°	0°	90°	0°	90°	0°	90°	0°	90°	0°	90°	0°	90°	0°	90°	0°	90°	0°	90°			
500	S06	152	119	188	155	224	191	260	227	296	263	333	299	369	335	405	371	441	407	513	480	76	115	13,3
	S08	131	86	167	122	203	158	239	194	275	231	311	267	347	303	383	339	419	375	492	447	101	153	13,8
	S10					181	126	217	162	254	198	290	234	326	270	362	306	398	342	470	414	126	192	14,4
	S12							196	129	232	165	268	201	304	238	340	274	376	310	449	382	152	230	14,9
	S14 (A)											247	169	283	205	319	241	355	277	427	349	177	268	15,4
850	S06	260	209	320	269	380	328	440	388	500	448	559	508	619	568	679	627	739	687	858	807	116	177	19,7
	S08	227	159	287	218	347	278	407	338	467	398	526	458	586	518	646	577	706	637	826	757	155	236	20,3
	S10			254	168	314	228	374	288	434	348	494	408	553	467	613	527	673	587	793	707	193	295	20,9
	S12							341	238	401	298	461	358	521	417	580	477	640	537	760	657	232	353	21,6
	S14 (A)											428	307	488	367	547	427	607	487	727	607	271	412	22,2
1200	S06	373	289	460	376	546	462	633	549	720	635	806	722	893	808	979	895	1066	981	1239	1154	171	271	30,1
	S08	325	213	411	299	498	386	584	472	671	559	758	645	844	732	931	818	1017	905	1190	1078	229	361	31,1
	S10	276	136	363	222	449	309	536	395	622	482	709	569	795	655	882	742	969	828	1142	1001	286	451	32,2
	S12					401	232	487	319	574	405	660	492	747	578	833	665	920	751	1093	924	343	541	33,2
	S14 (A)									525	329	612	415	698	502	785	588	871	675	1044	848	400	631	34,3
1750	S06	477	349	595	466	712	584	830	702	948	820	1066	937	1183	1055	1301	1173	1419	1291	1654	1526	270	421	39,3
	S08	400	229	518	347	636	465	754	582	871	700	989	818	1107	936	1225	1053	1342	1171	1578	1407	360	562	41,0
	S10			441	228	559	345	677	463	795	581	912	699	1030	816	1148	934	1266	1052	1501	1287	451	702	42,7
	S12							600	344	718	461	836	579	954	697	1071	815	1189	933	1425	1168	541	843	44,4
	S14 (A)									642	342	759	460	877	578	995	695	1113	813	1348	1049	631	983	46,0
2100	S06	702	509	883	690	1064	871	1245	1052	1426	1233	1607	1414	1788	1595	1969	1776	2150	1957	2512	2319	384	577	60,0
	S08	574	316	755	497	936	678	1117	859	1298	1040	1479	1221	1660	1402	1841	1583	2022	1764	2384	2126	512	770	62,0
	S10			627	305	808	486	989	667	1170	848	1351	1029	1532	1210	1713	1391	1894	1572	2256	1934	640	962	64,0
	S12							861	474	1042	655	1223	836	1404	1017	1585	1198	1766	1379	2128	1741	768	1154	66,0
	S14 (A)									914	463	1095	644	1276	825	1457	1006	1638	1187	2000	1549	896	1347	68,0
2500	S06	1299	1045	1587	1333	1876	1622	2164	1910	2453	2199	2741	2487	3029	2775	3318	3064	3606	3352	4183	3929	508	806	85,9
	S08	1155	816	1444	1105	1732	1393	2020	1682	2309	1970	2597	2258	2886	2547	3174	2835	3462	3124	4039	3700	677	1075	89,4
	S10			1300	876	1588	1165	1877	1453	2165	1742	2453	2030	2742	2318	3030	2607	3319	2895	3895	3472	846	1344	92,9
	S12					1444	936	1733	1225	2021	1513	2310	1802	2598	2090	2886	2378	3175	2667	3752	3243	1015	1613	96,4
	S14 (A)							1589	996	1877	1285	2166	1573	2454	1861	2742	2150	3031	2438	3608	3015	1184	1882	99,9
4000	S06	1763	1262	2165	1663	2566	2065	2967	2466	3369	2867	3770	3269									758	1348	158,7
	S08	1549	880	1950	1282	2351	1683	2752	2084	3154	2485	3555	2887	3956	3288	4358	3689	4759	4091	5068	4399	1011	1797	164,7
	S10					2136	1301	2538	1702	2939	2104	3340	2505	3742	2906	4143	3307	4544	3709	4853	4017	1264	2246	170,8
	S12							2323	1320	2724	1722	3125	2123	3527	2524	3928	2926	4329	3327	4638	3636	1516	2696	176,9
	S14 (A)											2911	1741	3312	2142	3713	2544	4115	2945	4423	3254	1769	3145	182,9

(A) Standaard

TYPE	Luchtvolume (l)		Tijd type ADA (s)		Tijd type ASR (s)	
	Openen	Sluiten	Openen	Sluiten	Openen	Sluiten
10	0,035	0,028	0,02	0,05	-	-
20	0,13	0,09	0,04	0,09	0,12	0,18
40	0,27	0,23	0,08	0,08	0,20	0,29
80	0,64	0,47	0,11	0,10	0,27	0,40
130	0,77	0,76	0,15	0,15	0,32	0,50
200	1,19	1,2	0,18	0,22	0,50	0,60
300	1,96	1,73	0,30	0,40	0,70	0,85
500	2,95	2,74	0,40	0,50	0,90	1,10
850	4,7	3,86	0,80	0,90	2,20	2,60
1200	6,95	4,64	1,20	1,50	2,30	2,80
1750	9,8	9,3	1,80	2,00	2,80	3,20
2100	11,6	10,2	2,30	2,60	3,30	3,70
2500	25	32	2,80	3,10	3,80	4,20
4000	33,2	27,5	3,00	3,50	4,30	5,00

Zonder belasting, stuurdruk 6 bar, standaard verenpakket

Het luchtverbruik is het vrij luchtvolume bij 1 atm